



# RT-40 Posi-Track<sup>®</sup>



## RT-40 Brief Specifications

Operating weight:	4,175 lbs   1,894 kg
Tipping load:	2,660 lbs   1,206 kg
Ground pressure:	3.5 psi   24.1 kPa
Gross engine power:	37.5 hp   27.9 kW

## OPERATING SPECIFICATIONS

Loader arms	Radial
Operating weight	4,175 lbs   1,894 kg
Shipping weight	3,767 lbs   1,709 kg
Ground pressure @ operating weight	3.5 psi   24.1 kPa
Rated operating capacity (35% of tipping load)	931 lbs   422 kg
Operating capacity (50% of tipping load)	1,330 lbs   603 kg
Tipping load	2,660 lbs   1,206 kg
Travel speed, maximum	7.1 mph   11.4 kph

## ENGINE

Type	Diesel, 3-cylinder, Turbocharged
Model	Kubota D1803-CR-T
Displacement	111.4 in <sup>3</sup>   1.82 L
Gross power rating @ 2800 rpm	37.5 hp   27.9 kW
Torque, peak	84.5 ft-lb   115.8 Nm
Cooling system	Engine-driven fan and coolant/anti-freeze-filled radiator
Intake air cleaner	Dual stage
Emission controls	Meets all U.S. EPA Tier 4 final standards

## UNDERCARRIAGE

Track type: General purpose track constructed of rubber compound with embedded co-polymer cords and all-purpose treads. Single row of track drive lugs molded in. Turf track with smooth tread available as an option.	
Track width	11 in   279 mm
Length of track on ground	55 in   1,397 mm
Ground contact area	1,210 in <sup>2</sup>   .78 m <sup>2</sup>
Drive system	Two hydrostatic direct drive sprockets controlled by a single joystick
Track drive sprocket	Elevated with low friction, replaceable sprocket rollers
Undercarriage suspension	2 independent torsion axles per undercarriage
Roller wheels	12 high-density polyurethane and rubber wheels per track. Wheels include sealed bearings
Roller wheel diameter	10 in   254 mm

## AUXILIARY HYDRAULIC SYSTEM

Pump capacity	13.3 gpm   50.35 lpm
System pressure, max.	3,000 psi   20,684 kPa
Controls	Intermittent via joystick button or continuous via console switch, mode selectable via dash-mounted switch
Couplers	Push-to-connect quick couplers mounted on loader arm. Pressure relief valve mounted to coupler block
Cooling system	High efficiency oil cooler beside engine radiator, not stacked
Standard features	Attachment control kit Manual quick-attach

## ELECTRICAL SYSTEM

Nominal charge	12 V
Battery	525 CCA
Charging system	60 amp alternator
Outlets	2 - 12 V ports inside operator station
Wiring	Pre-wired for all factory-available accessories
Standard features	Engine block heater

## OPERATOR STATION

Seat: Adjustable contour vinyl suspension seat with built-in operator presence switch, lap bar and 2-inch   51 mm wide seat belt.	
Loader control: Right-hand pilot hydraulic joystick controls loader lift, lower and tilt, plus intermittent control of auxiliary hydraulic.	
Drive control: Left-hand pilot hydraulic joystick controls machine speed and direction.	
Engine speed	Hand-operated rotary throttle.
Parking brake	Actuated by dash-mounted switch
Multi-Functional Display/Indicator	Engine oil pressure, Hydraulic oil temperature, Engine coolant temperature, Battery voltage, Hourmeter, Fuel level, Tachometer, Tripmeter.
ROPS	ISO 3471 2008-08-15, CAL OSHA 1596, 1999 subsect. (g) (9)
FOPS	ISO 3449: 2005-09
Operator restraint anchorage	ISO 6683:2005-01-15
Illumination	2 - Fixed forward-facing halogen lights 1 - Adjustable rear-facing halogen light 1 - Interior light
Convenience	2 - 12 V power ports
Standard features	Horn, backup alarm, rear window

# DIMENSIONS

# RT-40

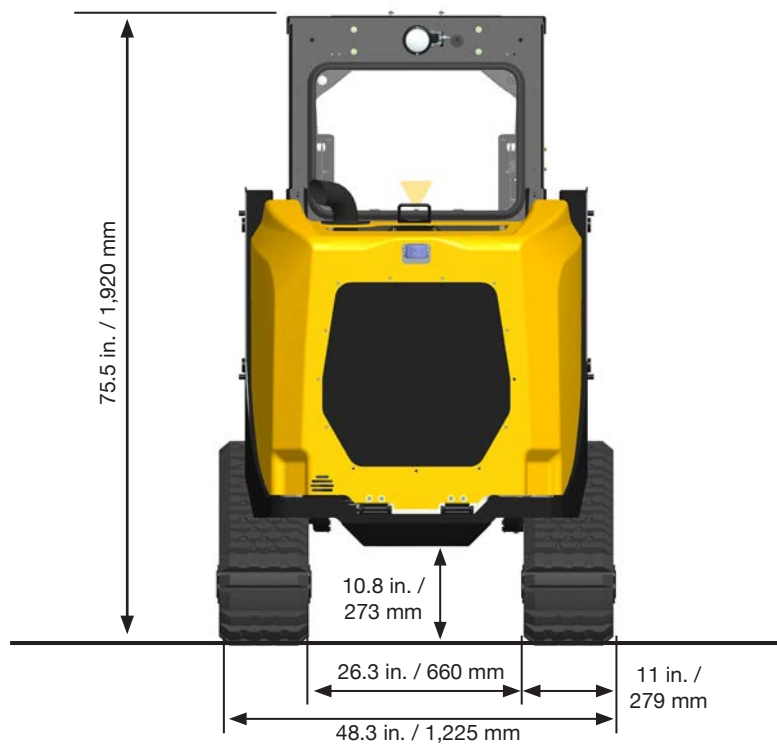
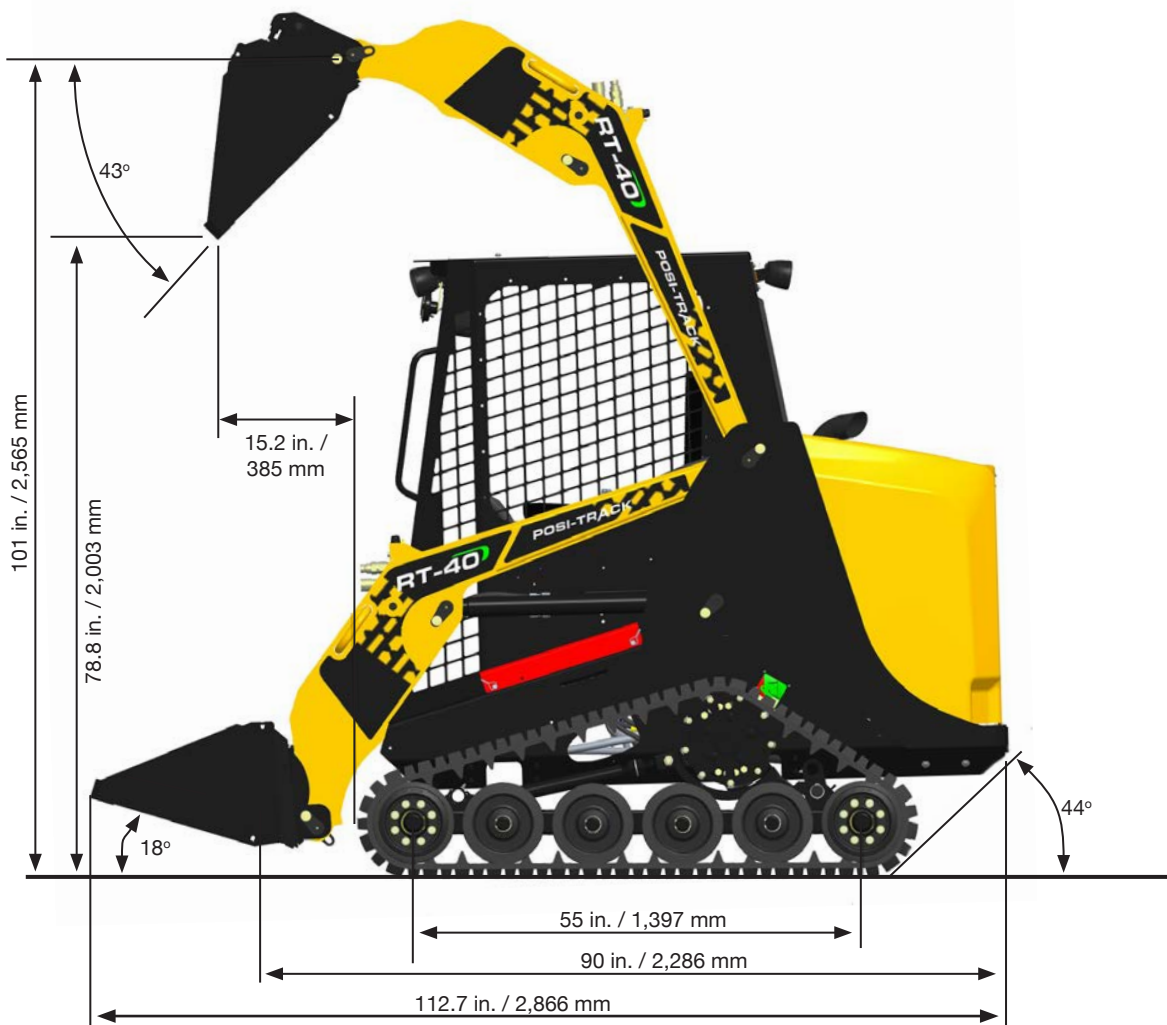

## SERVICE REFILL CAPACITIES

Fuel tank	13 gal   49 L
Hydraulic tank	3.5 gal   13.25 L
Engine coolant   antifreeze	1.8 gal   6.8 L
Engine oil, including filter	7.4 qt   7 L

**HAMRE EQUIPMENT**  
530-895-8955  
WWW.HAMREEQUIPMENT.COM

## OPTIONAL ATTACHMENTS

Auger drive and bits	Grapple bucket
Backhoe	Pallet forks
Broom, rotary	Power box rake
Bucket, general purpose	Snow blade
Bucket, light material	Snow blower
Bucket, multi-purpose	Stump grinder
Brush cutter, rotary	Trencher
Dozer blade	Vibratory roller
Eliminator rake	

Effective Date: March, 2018

Product specifications and prices are subject to change without notice or obligation. The photographs and/or drawings in this document are for illustrative purposes only. Refer to the appropriate Operator's Manual for instructions on the proper use of this equipment. Failure to follow the appropriate Operator's Manual when using our equipment or to otherwise act irresponsibly may result in serious injury or death. The only warranty applicable to our equipment is the standard written warranty applicable to the particular product and sale and ASV makes no other warranty, express or implied. © 2018 ASV Holdings, Inc. ASV, the ASV logo design and Posi-Track are trademarks of ASV Holdings, Inc.

### ASV Holdings, Inc.

840 Lily Lane  
Grand Rapids, MN  
55744-4089

Toll-free: (800) 205-9913  
Fax: (218) 327-2297  
www.asvi.com

