



RT-120

Compact Track Loader



RT-120

Brief Specifications

Operating weight:	11,265 lbs 5110 kg
Tipping load:	10,100 lbs 4581 kg
Ground pressure:	4.4 psi 30.3 kPa
Gross engine power	120 hp 89.5 kW

OPERATING SPECIFICATIONS

Loader arms	Radial
Operating weight	11,265 lbs 5110 kg
Shipping weight	10,391 lbs 4713 kg
Ground pressure @ operating weight	4.4 psi 30.3 kPa
Rated operating capacity, 35% of tipping load	3,535 lbs 1603 kg
Operating capacity, 50% of tipping load	5,050 lbs 2291 kg
Tipping load	10,100 lbs 4581 kg
Travel speed, maximum - 1 st speed	6 mph 9.7 kph
Travel speed, maximum - 2 nd Speed	10 mph 16 kph

ENGINE

Type	Diesel, 4-cylinder, intercooled, turbocharged
Model	Cummins QSF3.8
Displacement	232 in ³ 3.8 L
Gross power rating @ 2800 rpm	120 hp 89.5 kW
Torque, peak	360 ft-lb 488 Nm
Cooling system	Temperature-controlled, variable speed hydraulically-driven fan and coolant/anti-freeze-filled radiator
Intake air cleaner	Three-stage
Emission controls	Meets all U.S. EPA Tier 4 final standards
Standard feature	Auto idle

UNDERCARRIAGE

Track type: General purpose track constructed of rubber compound with embedded co-polymer cords and all-purpose treads.	
Track width	18 in. 457 mm
Length of track on ground	71 in 1803 mm
Ground contact area	2,556 in ² 1.65 m ²
Drive system	Two hydrostatic direct drive sprockets controlled by a single joystick
Track drive sprocket	Elevated with low friction, replaceable sprocket rollers
Undercarriage suspension	Two independent torsion axles per undercarriage
Roller wheels	24 high-density polyurethane and rubber wheels per track. Wheels include sealed bearings
Roller wheel diameter:	
Front and rear wheels	15 in. 381 mm
Middle wheels	10 in. 254 mm

* Machine tested with foundry bucket

AUX. HYDRAULIC SYSTEM

Pump capacity:	Low - variable from 0-20 gpm 75.7 lpm. High - variable from 30 gpm 114 lpm to 45 gpm 170 lpm
System pressure,	Low - 3,300 psi 22 750 kPa High - 4,060 psi 27 993 kPa
Controls	Intermittent via joystick button or continuous via console switch. High-flow is adjustable and loader/auxiliary sharing is adjustable via machine display
Couplers	Push-to-connect quick couplers mounted on loader arms. Pressure relief valve on coupler block
Cooling system	High efficiency side-by-side radiator and oil cooler

ELECTRICAL SYSTEM

Nominal charge	12 V
Battery	950 CCA
Charging system	120 amp alternator
Outlets	1-12 V port inside operator station
Wiring	Pre-wired for all factory-available accessories
Standard features	Attachment control kit, block heater

OPERATOR STATION

Seat: Adjustable contour vinyl with built-in operator presence switch, lap bar and 2 in 51 mm wide seat belt	
Loader control: Right-hand pilot electronic joystick controls loader lift, lower and tilt, plus intermittent control of auxiliary hydraulic. Loader speed is adjustable and selectable from ISO or H control pattern.	
Drive control: Left-hand pilot electronic joystick controls machine speed and direction. Track speed is adjustable, includes a Creep Mode and is selectable from ISO or H control pattern.	
Engine speed	Hand-operated throttle
Machine display	Engine RPM, fuel level, coolant temperature, air inlet temperature, engine oil pressure, voltage, hydraulic oil temperature, travel speed, DEF level, engine hourmeter, trip meter self-diagnostics including stored history, air filter indicator, loader/aux. hydraulic sharing, auxiliary hydraulic flow, winch (optional) control
ROPS	Meets ISO 3471:2008, ISO 6683:2005
FOPS	Meets ISO 3449:2005 level 1, SAE J386:2006-2
Illumination	2 - Adjustable forward-facing halogen lights 2 - Adjustable rear-facing halogen lights 1 - Interior light
Convenience	12 V power port
Standard features	Horn, backup alarm, rear-view camera

DIMENSIONS

RT-120

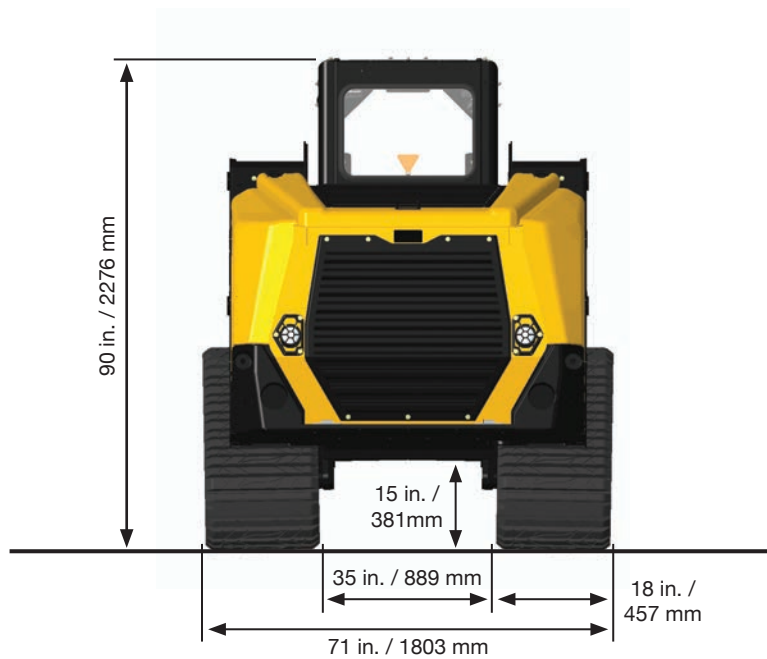
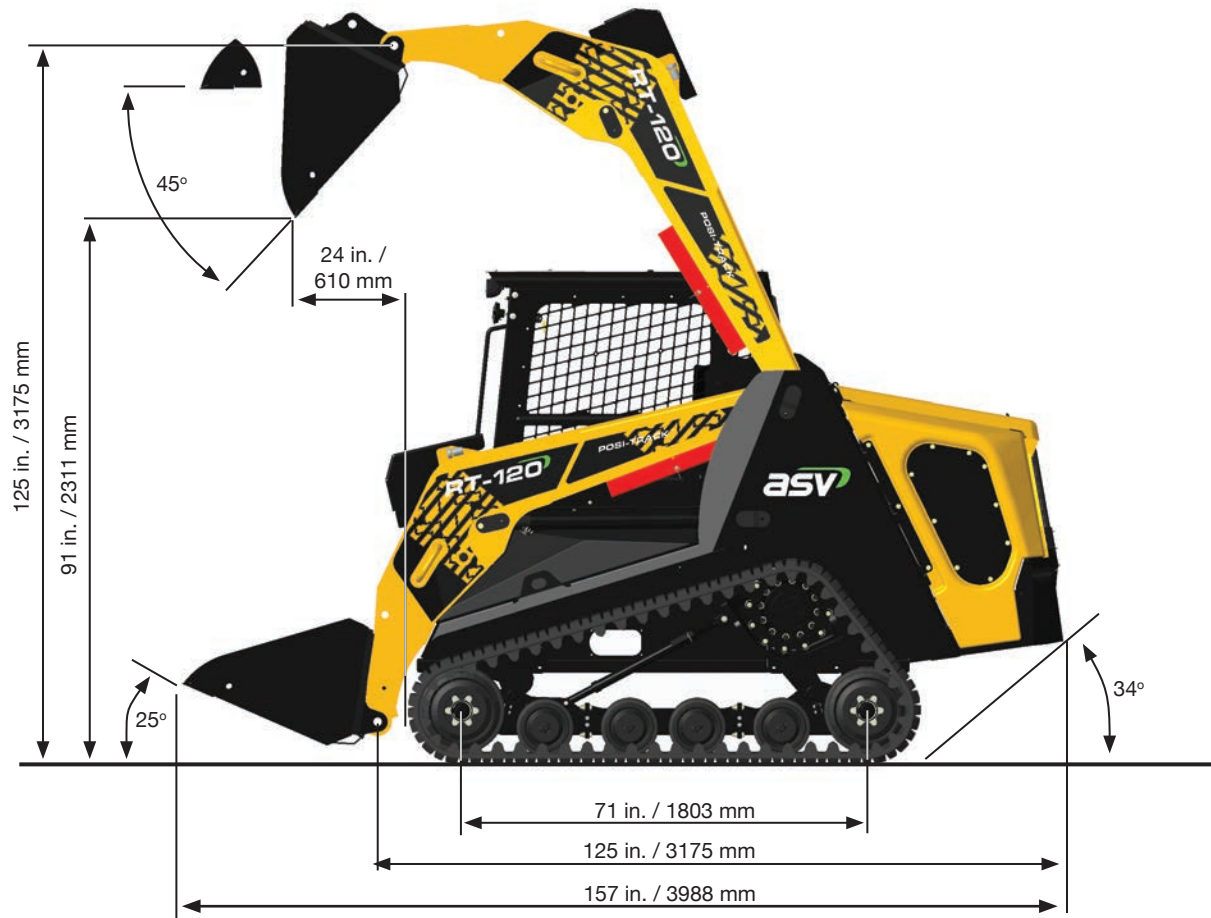

SERVICE REFILL CAPACITIES

Fuel tank	30 gal 114 L
Hydraulic tank	22 gal 83 L
Engine coolant/antifreeze	5.5 gal 20.8 L
Engine oil, including filter	12 quarts 11.4 L

OPTIONAL ATTACHMENTS

Dirt bucket, 72 inch 1829 mm wide, or
Dirt Bucket, 74 inch 1880 mm wide
Tooth bar, 72 inch 1829 mm wide, or
Tooth bar, 74 inch 1880 mm wide

HAMRE EQUIPMENT
530-895-8955
WWW.HAMREEQUIPMENT.COM

Effective Date: May 2016

Product specifications and prices are subject to change without notice or obligation. The photographs and/or drawings in this document are for illustrative purposes only. Refer to the appropriate Operator's Manual for instructions on the proper use of this equipment. Failure to follow the appropriate Operator's Manual when using our equipment or to otherwise act irresponsibly may result in serious injury or death. The only warranty applicable to our equipment is the standard written warranty applicable to the particular product and sale and ASV makes no other warranty, express or implied. © 2017 ASV Holdings, Inc. ASV, the ASV logo design and Positrack are trademarks of ASV Holdings, Inc.

ASV Holdings, Inc.

840 Lily Lane
Grand Rapids, MN
55744-4089

Toll-free: (800) 205-9913
Fax: (218) 327-2297
www.asvi.com

